



Model FT-1

Refrigerated Drop-In Frost Tops

Model

- FT-1
- FT-2
- FT-3
- FT-4
- FT-5
- FT-6

STANDARD FEATURES

- ☑ Self contained drop-in design
- ☑ Hold standard 18" by 26" sheet pans or 1/2 size pans
- ☑ Stainless steel top and liner for maximum strength and durability
- ☑ 1" drain for ease of cleaning
- ☑ On-off switch with 8 ft. cord & plug for ease of installation and operation
- ☑ Type 134A CFC free refrigerants
- ☑ Fully insulated, CFC free, foamed-in place for energy savings
- ☑ Quick & easy service with sight glass, service valves, filter/dryer and receiver
- ☑ Limited 1 year parts & labor warranty

OPTIONS & ACCESSORIES

- ☑ Condenser orientation and compressor rack location
- Remote on/off switch
- ☑ 220/230/240V
- ☑ 50 cycle
- ☑ Remote models (Includes compressor and condensing units and up to 20' leads)
- ☑ Remote models without compressors or condensing units

DESCRIPTION

USECO Refrigerated Drop-In Frost Tops are designed to keep pre-chilled food and beverage products at cold, fresh serving temperatures. All models are completely self-contained. Each section holds a full-size sheet pan and is available from one to six size pan models, are CFC free and include an 8 ft. 120V cord and plug.

SPECIFICATIONS

7RS-LHWDP SHGW DLOHWHHOERWUFWLRQWDBUDL
 IRUBDHBEIOHDLWEDDFRPPRGDWHDOIDGIDOOH
 HHWSDEBDWUHDGMWDEOHWHPSHUDWUHERWURO
 WHULRU&WHHODWLRBQGHGGERWWRP
 &RGHLQERWHGBERUURLRQHLWDWWDPHHOR
 WHEROGSD

HIULHUDWLRBIULHUDWLRERLODUHDWDFHGWRRWH
 GHULGHEIWHWRWRSRUBDLPPPIFLHFDGERRO
 GGLWLRDOERLODURGWHDGHEIWHWRWRSRU
 FRPSOHWHERYHUDHQUERROHG&WHHDIULHUDWHP
 IHDWUHBQIERWDLHGERGHHUJGGBDOHGERPSUHRU
 DGBBIIQDFLQWERUGDGSQBWBILHUDWLR
 WHPHWDWUHDWDEDBUYLFHDOYHGUHUQWU
 DGDHFHLYHU&RGHLQWEDBEHBDLQHPRYHGURU
 HUYLEFH



Model AFCP3-SLST

shown below

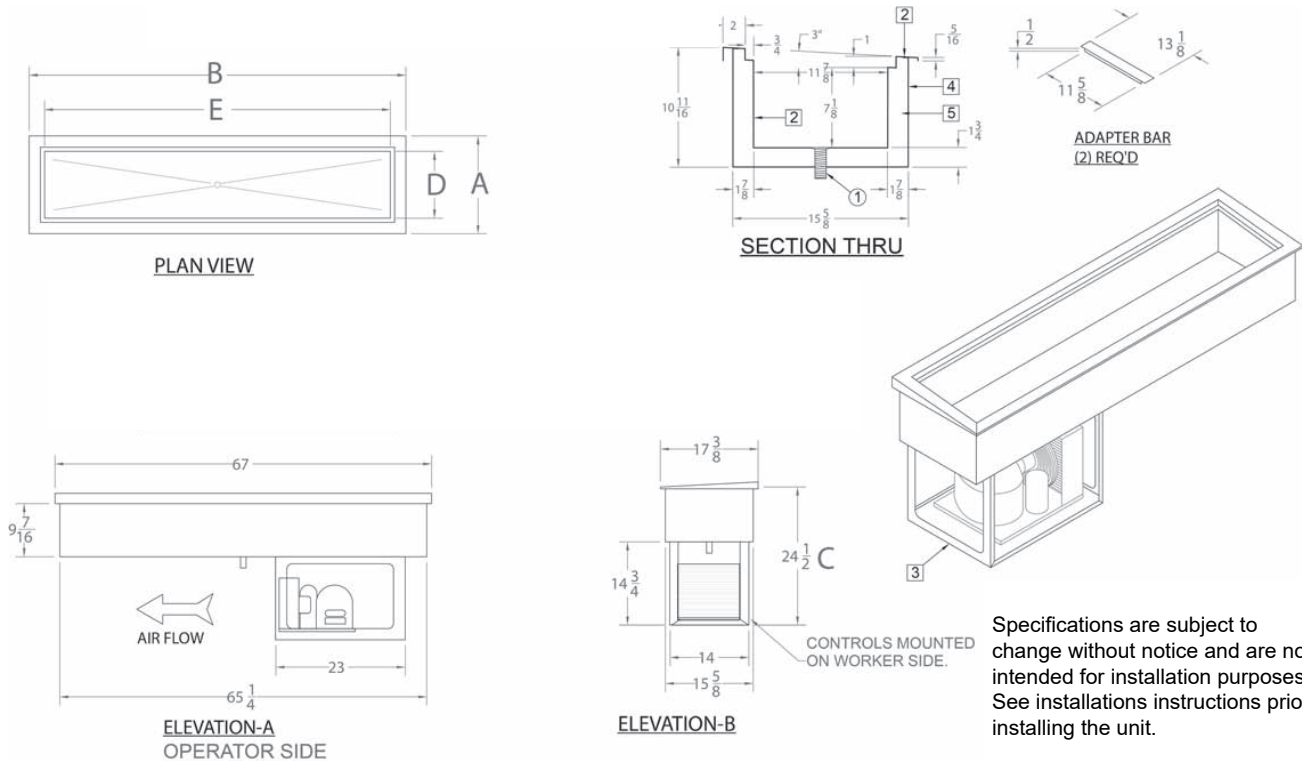

SPECIFICATIONS								SHIPPING INFORMATION							
Model Number	OVERALL DIMENSIONS			INTERIOR DIMENSIONS		CUT OUT DIMENSIONS		WEIGHTS		CARTON DIMENSIONS			CRATE SIZE		
	A Front to Back Inches (MM)	B Left to Right Inches (MM)	C Height Inches (MM)	D Front to Back Inches (MM)	E Left to Right Inches (MM)	Width Front to Back Inches (MM)	Length Left to Right Inches (MM)	Model Number	SHIPPING WEIGHT POUNDS (KG)	INSTALLED WEIGHT POUNDS (KG)	WIDTH Inches (MM)	DEPTH Inches (MM)	HEIGHT Inches (MM)	CUBIC FEET	CUBIC METERS
AFCP2-SLST	17-3/8 (441)	46-1/4 (1175)	24-1/2 (622)	11-7/8 (302)	40-3/4 (1035)	15-7/8 (403)	44-3/4 (1137)	AFC2-SLST	182 (83)	176 (80)	27 (686)	32 (813)	32 (813)	16	0.45
AFCP3-SLST	17-3/8 (441)	67 (1702)	24-1/2 (622)	11-7/8 (302)	61-1/2 (1562)	15-7/8 (403)	65-1/2 (1664)	AFCP3-SLST	194 (88)	187 (85)	27 (686)	46 (1168)	32 (813)	23	0.65

POWER SUPPLY

Model Number	VOLTS	HP	AMPS	PHASE	POWER SUPPLY	REFRIGERANT
AFCP2-SLST	115	1/4	4.9	SINGLE	NEMA 5-15P	134A
AFCP3-SLST	115	1/3	5.6	SINGLE	NEMA 5-15P	404A



5-15P